

Analysis of Frame Exposed to Fire

INTRODUCTION

In his study an analysis of steel frame exposed to fire was conducted. The frame was made from sections with corrugated webs called SIN profiles. In further analysis only a clipping of a spandrel beam of this frame was taken into account. On the basis of EC3 a material properties for sections in specific temperature were determined and for those properties a nonlinear static analysis of the clipping of the spandrel beam up to failure was carried out. Every analysis was conducted with reference to specific time of fire of this frame.

1. Geometry and material properties

The frame was made from sections with corrugated webs called SIN profiles. The geometry of analysed frame were presented in Fig.1. Typical loads acting on frame i.e. dead load of frame, steady load from roof and purlins and snow load were presented in Fig. 2, 3, 4, 5 respectively. Basic material properties i.e. in normal temperature 20°C were set up in Tab. 1. Bending moment of a clipping were presented in Fig.6

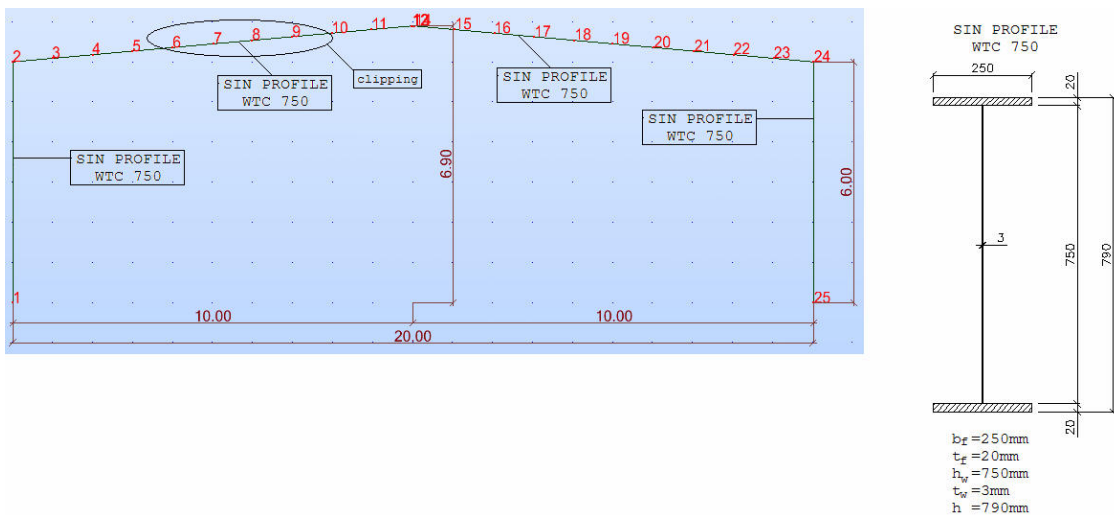

Fig. 1 Geometry and section properties of analysed frame

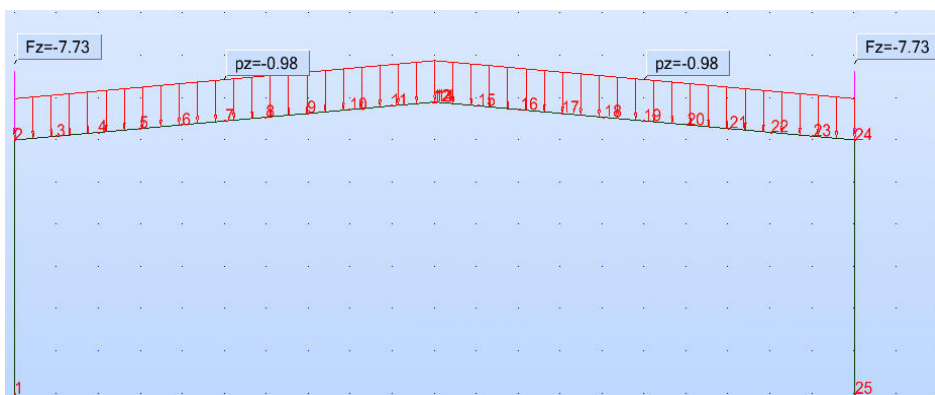

Fig. 2 Dead load

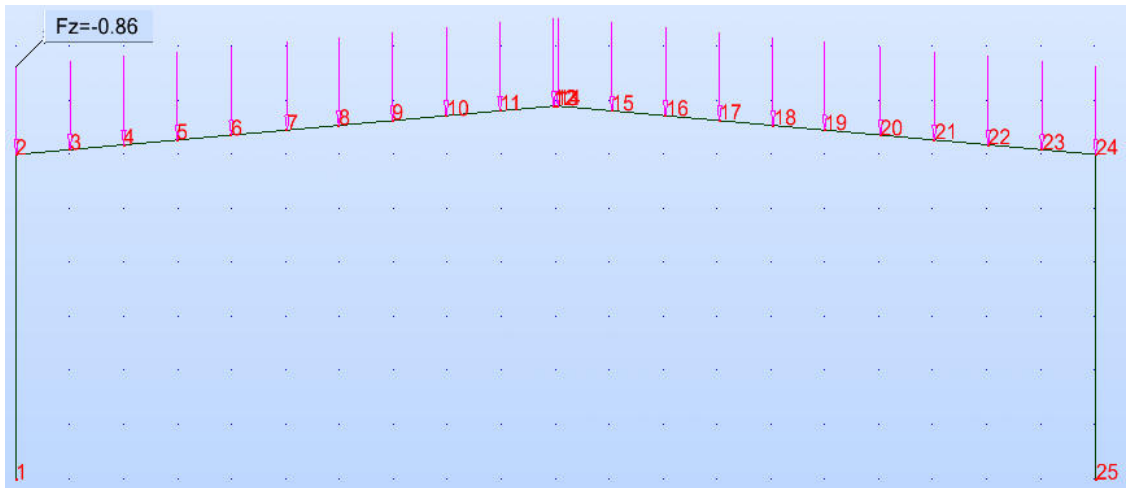

Fig.3 Steady load of roof

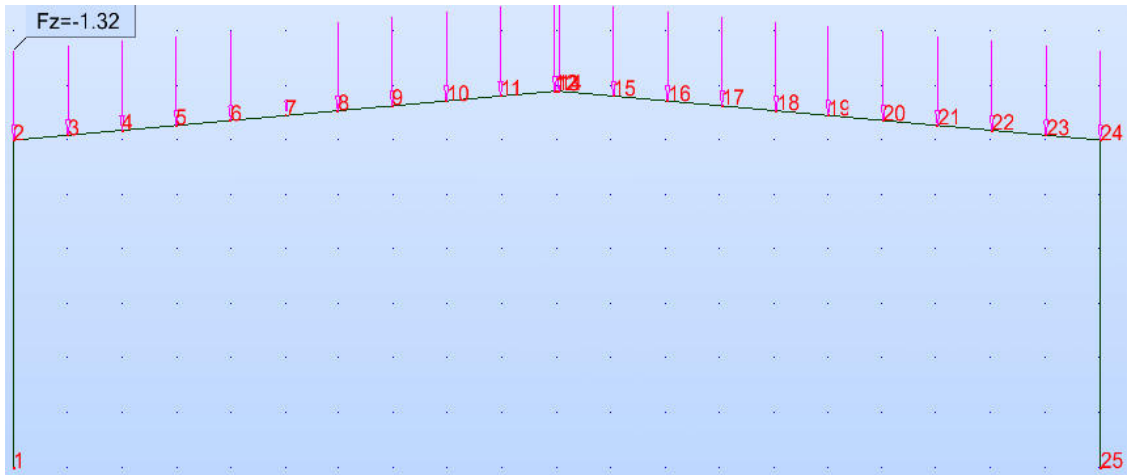

Fig.4 Steady load of purlins

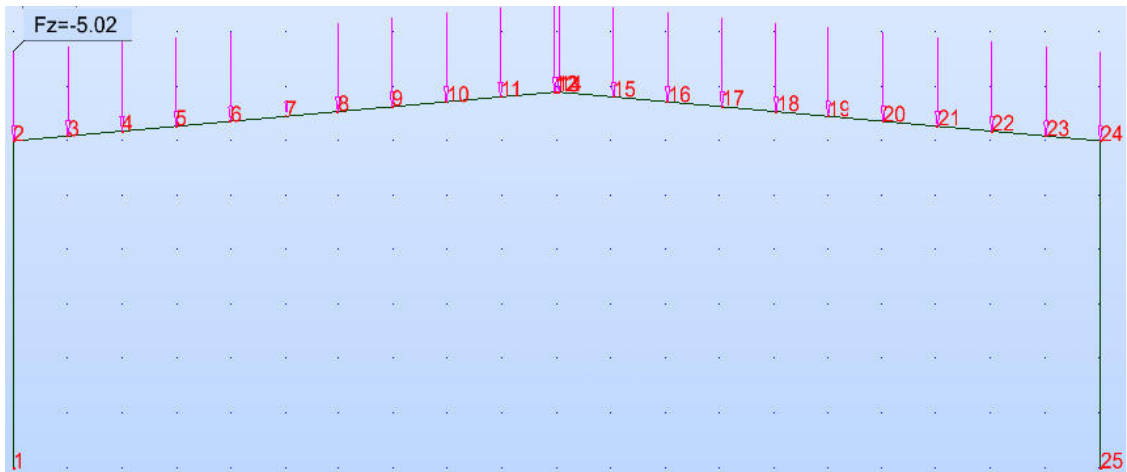

Fig. 5 Snow load

Tab. 1 Material properties for web and flanges in temperature 20°C

T_w [°C]	T_f [°C]	f_{yw} [MPa]	f_{yf} [MPa]	E_w [GPa]	E_f [GPa]
20	20	215	240	210	210

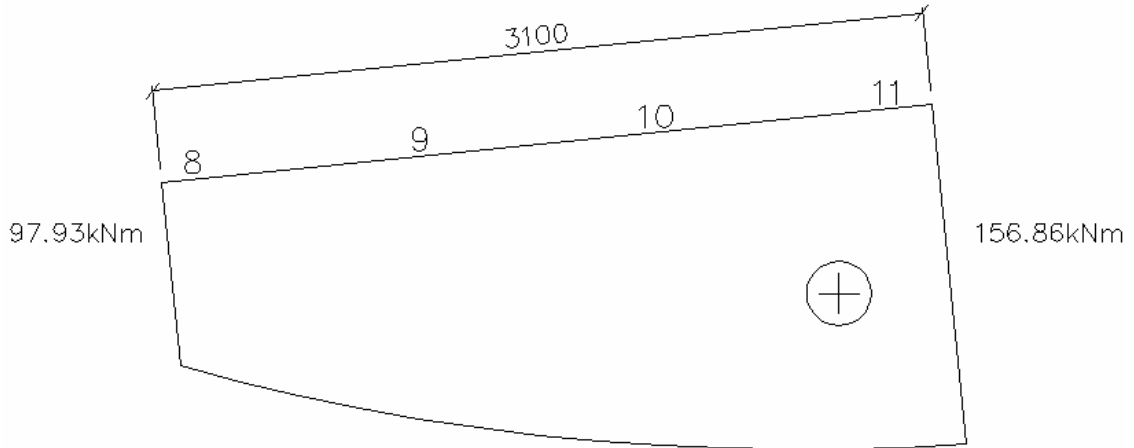

Fig. 6 Bending moment of a clipping

2. Numerical model

Numerical model was created with use of programme ABAQUS. The main structure was modelled with use of 4 node shell finite elements called S4R5. An MPC option was used to determined behaviour of whole external sections where boundary conditions were applied. Additional boundary conditions where applied to prevent model from global buckling in out of plane of web direction. In every case i.e. in specific temperature load – displacement curves were determined. The FEM model was presented in Fig. 8.

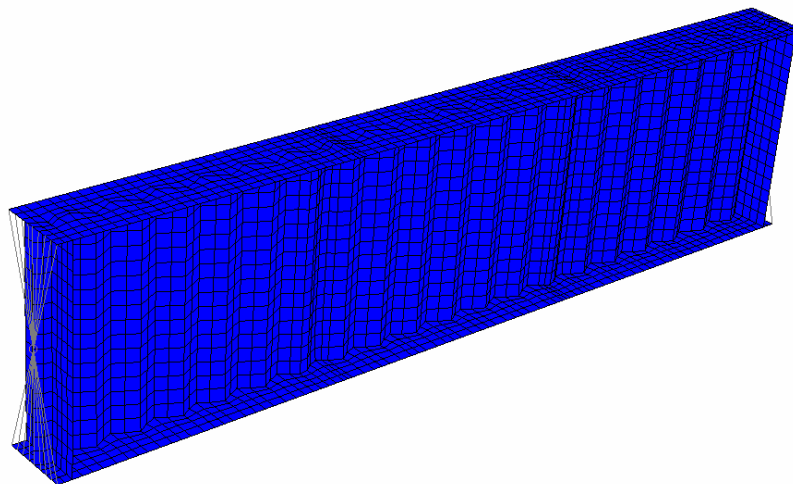

Fig. 7 Numerical model of a clipping

3. Static analysis

3.1 Material properties

On the basis of EC3 a material properties for sections in specific temperature were determined and for those properties a nonlinear static analysis of the clipping of the spandrel beam up to failure was carried out. Material properties in specific temperature were calculated by multiplying basic material properties (c.f. Tab.1) by specific coefficients with were taken from table 3.1 in EC3. This table is presented in Fig. 7. Calculated material properties for web and flanges were set up in Tab. 2 for time of 35min of fire and for time from 20 to 25min in Tab. 3 respectively.

Tab. 2 Material properties for time 0min to 35min

t [min]	T_w [°C]	T_f [°C]	f_{yw} [MPa]	f_{yf} [MPa]	E_w [GPa]	E_f [GPa]
0	20	20	215	240	210	210
5	103.9	36.4	215	240	209.18	210
10	211.5	86.8	215	240	186.59	210
15	334.5	173.3	215	240	160.75	194.61
20	488.9	300.4	172.95	240	128.33	167.92
25	847.9	655.7	18.50	80.72	16.64	44.05
30	980.7	861.1	9.43	19.07	10.36	16.01
35	1107.8	1069.3	3.96	6.27	4.36	10.90

Tab. 3 Material properties for time 20min to 25min

t [min]	T_w [°C]	T_f [°C]	f_{yw} [MPa]	f_{yf} [MPa]	E_w [GPa]	E_f [GPa]
20	488.9	300.4	172.95	240	128.33	167.92
20.5	621.3	321.6	90.06	240	57.05	163.46
21	753.8	359.0	35.57	240	22.78	155.61
21.5	764.2	406.5	32.89	236.57	21.91	145.64
22	774.6	450.7	30.20	213.23	21.03	136.35
22.5	786.1	491.8	27.24	191.53	20.07	127.72
23	797.7	529.7	24.24	165.10	19.10	107.91
23.5	810.0	564.9	22.58	138.91	18.43	86.48
24	822.3	597.3	21.25	114.81	17.85	66.74
24.5	835.1	627.5	19.89	96.96	17.24	54.71
25	847.9	655.7	18.50	80.72	16.64	44.05

Tabelle 3.1: Abminderungsfaktoren für die Spannungs-Dehnungsbeziehung von Kohlenstoffstahl unter erhöhter Temperatur

Stahltemperatur θ_s	Abminderungsfaktoren bei Temperatur θ_s relativ zu dem Wert f_y oder E_s bei 20°C		
	Abminderungsfaktor (relativ zu f_y) für die effektive Fließgrenze $k_{y,\theta} = f_{y,\theta}/f_y$	Abminderungsfaktor (relativ zu f_y) für die Proportionalitätsgrenze $k_{p,\theta} = f_{p,\theta}/f_y$	Abminderungsfaktor (relativ zu E_s) für die Steigung im elastischen Bereich $k_{E,\theta} = E_{s,\theta}/E_s$
20°C	1,000	1,000	1,000
100°C	1,000	1,000	1,000
200°C	1,000	0,807	0,900
300°C	1,000	0,613	0,800
400°C	1,000	0,420	0,700
500°C	0,780	0,360	0,600
600°C	0,470	0,180	0,310
700°C	0,230	0,075	0,130
800°C	0,110	0,050	0,090
900°C	0,060	0,0375	0,0675
1000°C	0,040	0,0250	0,0450
1100°C	0,020	0,0125	0,0225
1200°C	0,000	0,0000	0,0000

Anmerkung: Zwischenwerte dürfen linear interpoliert werden.

Fig. 8 Coefficients used in calculations of material properties

3.2 Types of analysis

In this study 2 types of static analysis was taken into account. The first of them was linear static analysis called **STATIC GENERAL (SG)** to determined internal forces for normal use of a structure i.e. temperature of normal exploitation 20°C (c.f. Fig. 6). The second analysis was nonlinear static analysis up to failure called **STATIC RIKS (SR)** to determined carrying capacity in every case i.e. in every temperature in specific time of fire. The results gained from SR were compared with those from SG to claim how long can this structure carry loads in fire. In SR two types of static skins of a clipping were analysed i.e. simple supported beam and cantilever beam while in SG only cantilever beam.

3.3 Results of SR

3.3.1 Simple supported beam

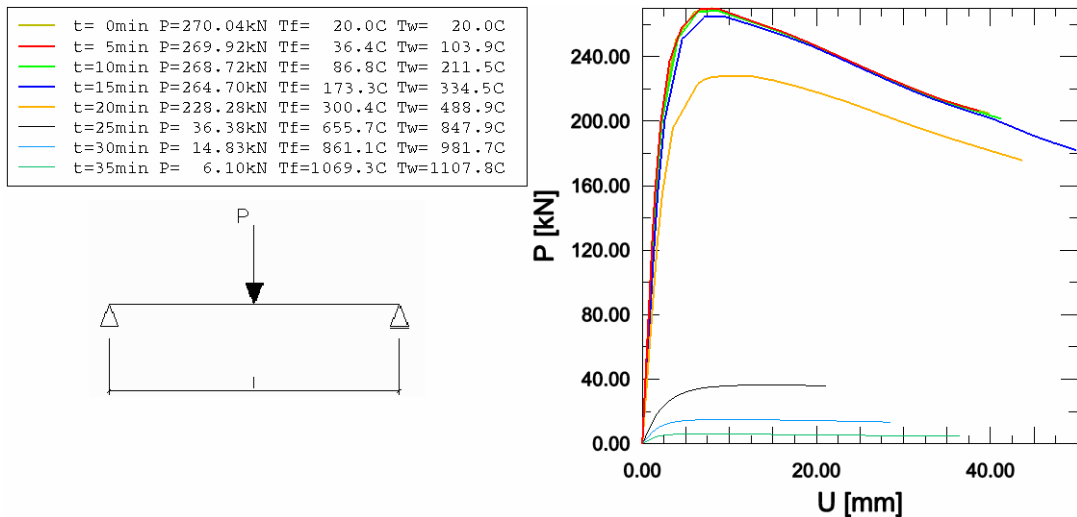

Fig. 9 Load – displacement curves for time from 0min to 35min of a fire

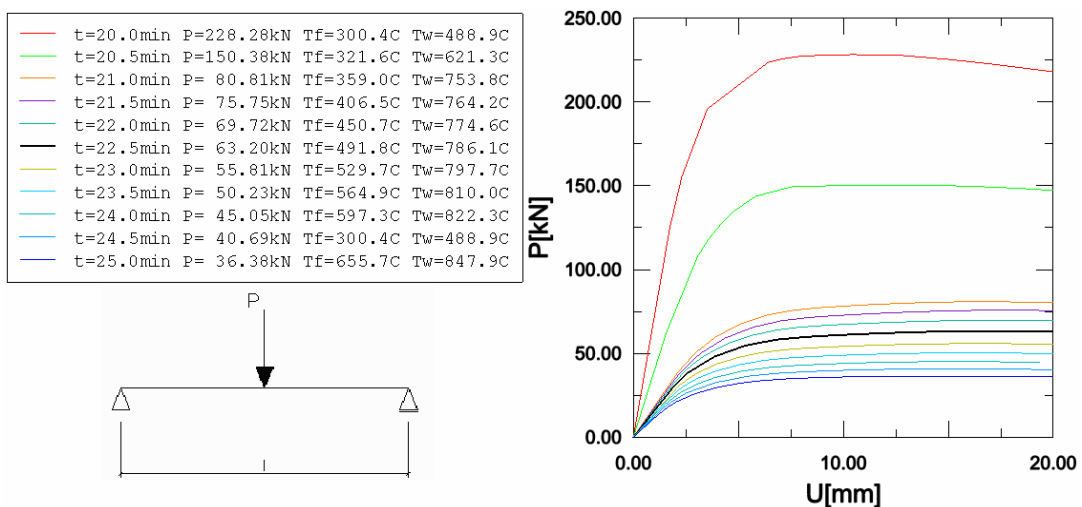

Fig. 10 Load – displacement curves for time from 20min to 25min of a fire

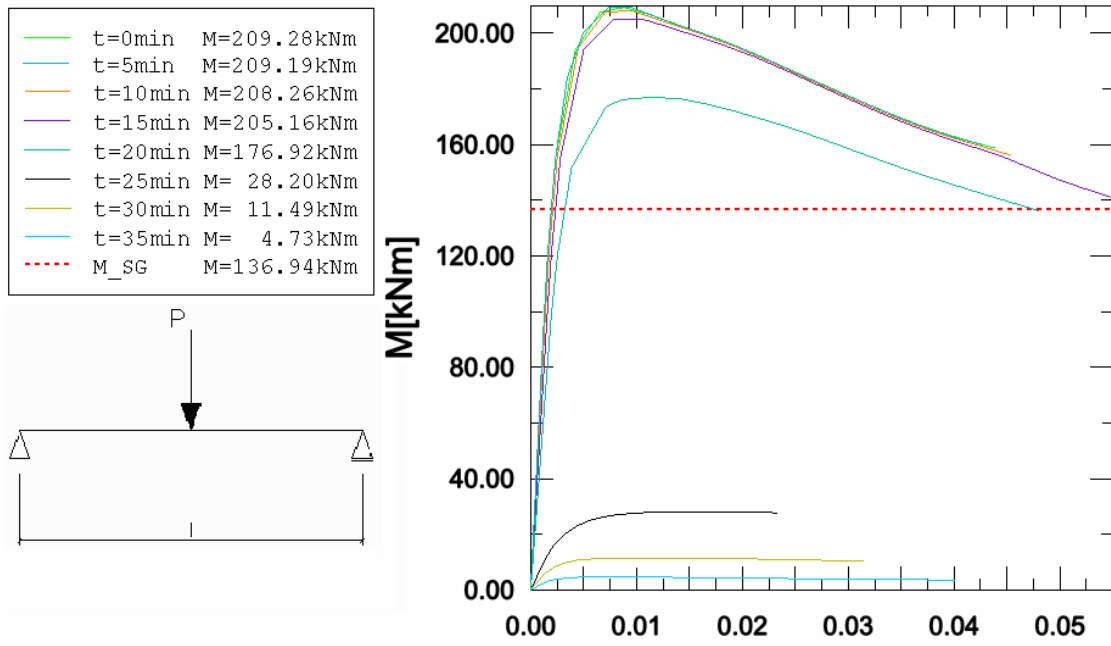

Fig. 11 Comparison of bending moments in middle section of beam for all types of analysis

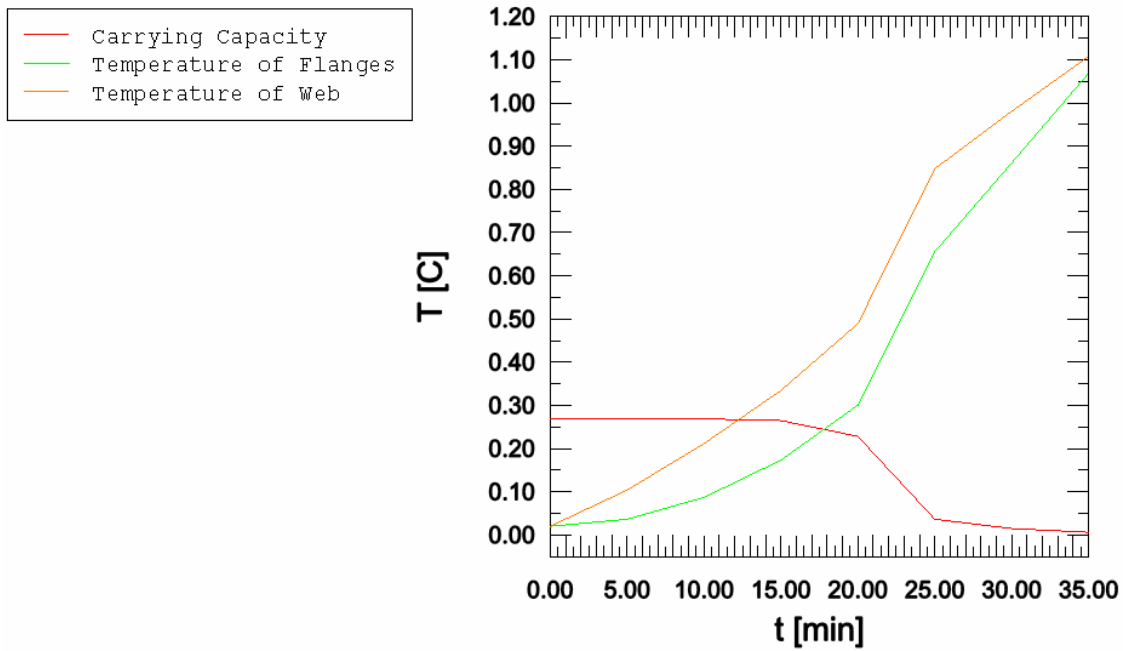

Fig. 12 Comparison of carrying capacity with temperature of web and flanges in 35min of fire

3.3.2 Cantilever beam

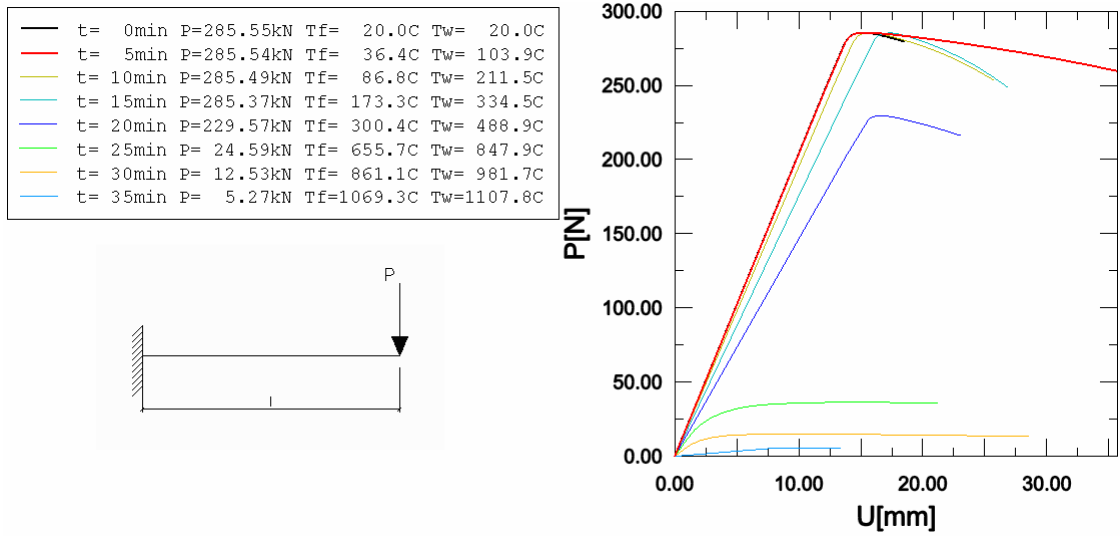

Fig. 13 Load – displacement curves for time from 0min to 35min of a fire

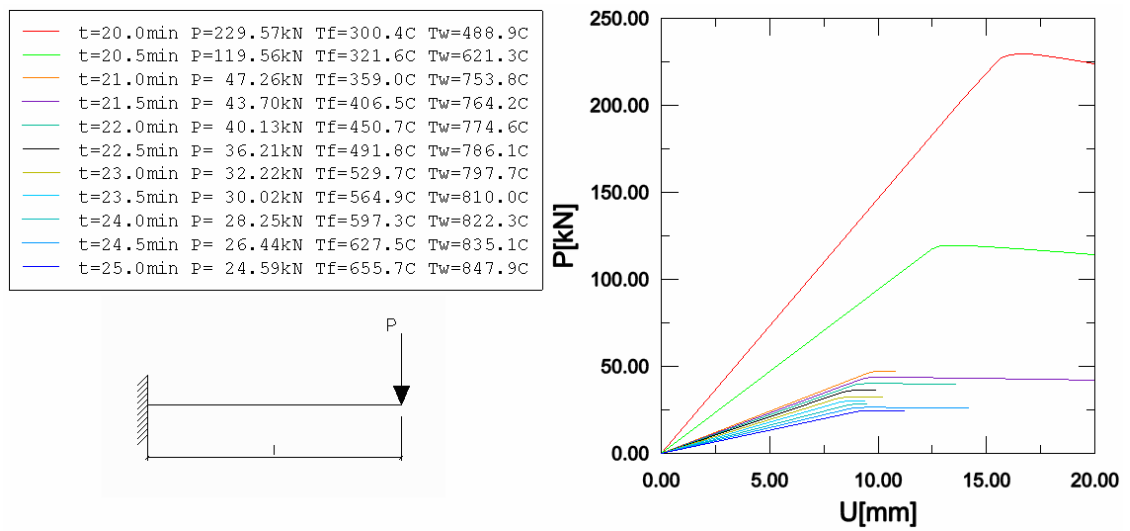

Fig. 14 Load – displacement curves for time from 20min to 25min of a fire

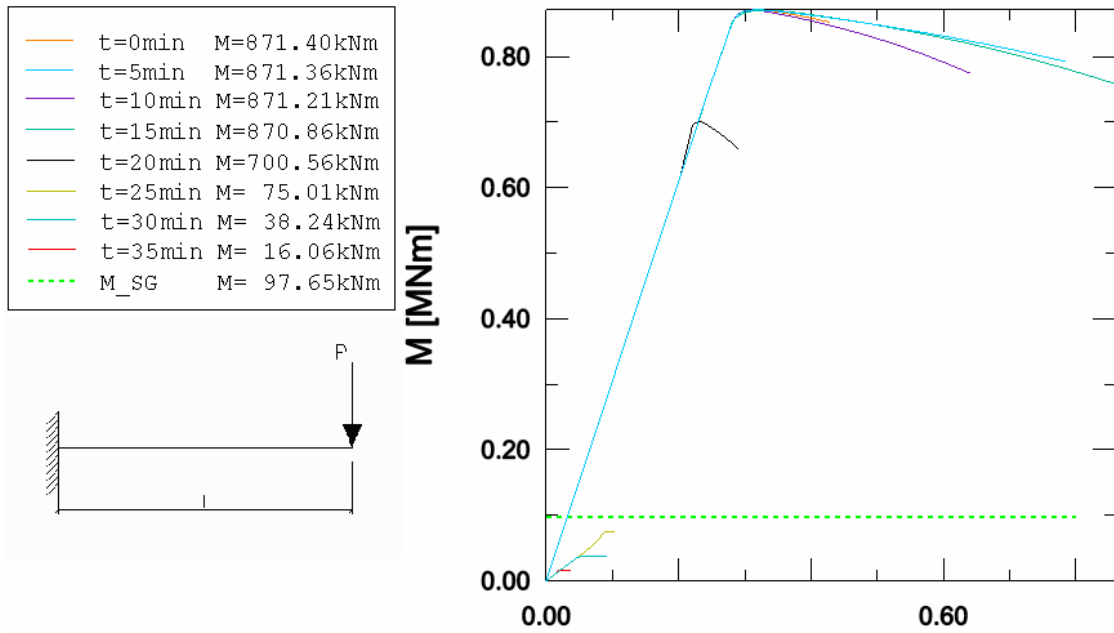

Fig. 15 Comparison of bending moments in encastre of beam for all types of analysis

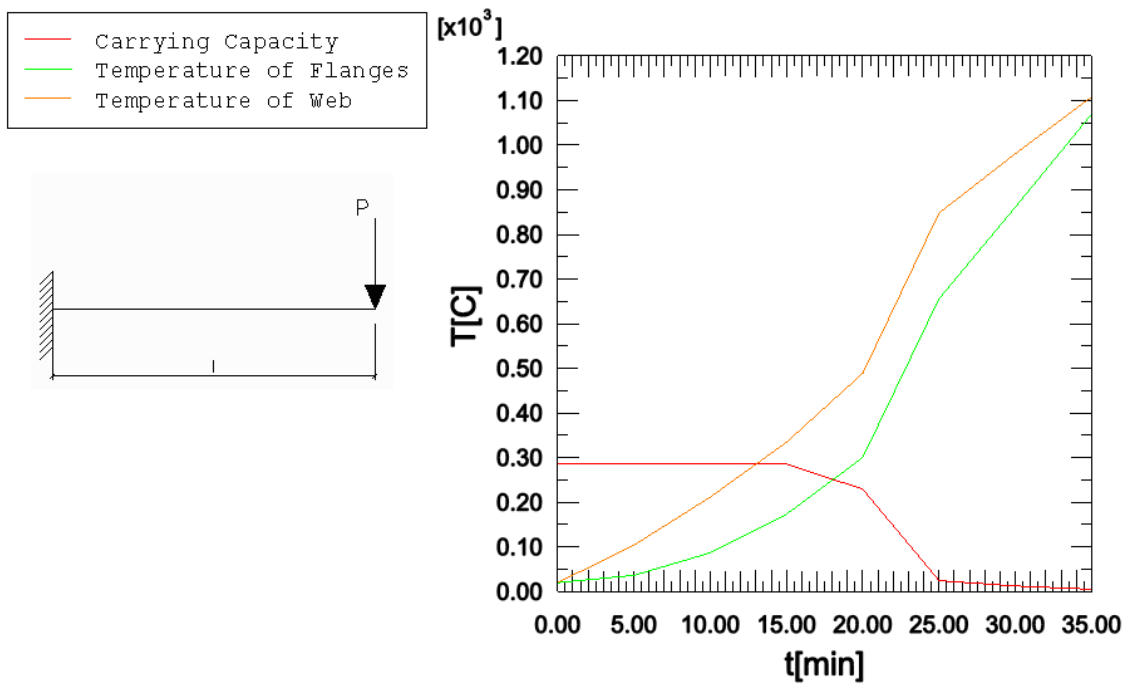

Fig. 16 Comparison of carrying capacity with temperature of web and flanges in 35min of fire